

# Opticom™ Pre-Loaded Fibre Drawers

# PANDUIT®

SPECIFICATION SHEET

## specifications

Pre-loaded fibre drawers provide a pre-configured, ready-to-install system for managing fibre optic terminations, connections and patching in a 1 RU rack mount enclosure. The pre-loaded enclosure accommodates both field termination and field splicing, and supports trunk cable entry via PG style glands, blown fibre glands and metric knockouts with rubber grommets. The pre-loaded enclosure is a two-piece design with a slide-out drawer for full access to all fibre terminations, easy moves, adds and changes and simple installation. The enclosure has silk-screened white areas adjacent to each adapter for individual fibre channel labelling and a similar silk-screen area for overall enclosure labelling. The enclosure has integral mounting brackets suitable for installation in any 19" wide EIA-310/IEC 60297 compatible rack or cabinet.



## technical information

<b>Dimensions:</b>	1.73"H x 17.50"W x 12.13" (43.9mm x 444.5mm x 308.2mm)
<b>Mounting option:</b>	Integral brackets mount to 19" wide EIA-310/IEC 60297 rack rails
<b>Accessories:</b>	Mounting hardware and fibre routing accessory kit included; contains two FMS1 fibre management spools, two 30mm size rubber grommets, one PG11 cable gland, Panduit™ Pan-Ty™ Cable Ties and M6 x 1 mounting screws

## key features and benefits

<b>Pre-loaded with fibre optic adapters</b>	Factory configured with duplex SC, LC or E-2000 adapters for fast and easy cabling and installation
<b>Slide-out drawer</b>	Slides forward a full 300mm for service access to all fibre terminations, connections and splices
<b>Field terminate or fusion splice</b>	Supports both field termination via pot-and-polish or Panduit™ Opticom™ Connectors or field splicing (fusion or mechanical) with appropriate slack storage and cable management provisions
<b>Multiple cable entry methods</b>	Trunk and interconnect cable entry via PG11 glands, 5mm blown fibre glands, 20mm knockouts or 30mm rubber grommets
<b>Two-piece, all-metal body construction</b>	Simple and economical installation with no loose components to misplace; improved protection over plastic fibre drawers
<b>Dedicated labelling areas</b>	Silk-screened white labelling areas for individual fibre channel identification plus overall enclosure labelling

## applications

Opticom™ Pre-Loaded Fibre Drawers provide a factory configured, ready to install system for managing fibre optic terminations, connections and patching in a variety of applications. The enclosure can serve as a transition from backbone cabling to distribution switching in telecommunications rooms, can act as an interconnect to active equipment switches in a fibre to the zone application, or can be used as a transition enclosure for splicing to service provider trunks and then patching to premise intra-building cabling.

The pre-loaded enclosures can terminate and manage up to 48 fibres in 1 RU depending on configuration and adapter type. Enclosures are pre-loaded with SC, LC or E-2000 style adapters suitable for use with 62.5/125µm (OM1), 50/125µm (OM2 or OM3/OM4) multimode or OS1/OS2 singlemode fibre. The simple two-piece design features a slide-out drawer for full access to all fibre terminations. This supports fast and intuitive installation plus easy moves, adds and changes.

[www.panduit.com](http://www.panduit.com)

### Opticom™ Pre-Loaded Fibre Drawer for OM1 62.5/125µm Multimode Fibre – Phos. Bronze Sleeve

6 duplex SC adapters:	FD1W6EIDSC
12 duplex SC adapters:	FD1W12EIDSC
24 duplex SC adapters:	FD1W24EIDSC
12 duplex LC adapters:	FD1W12EIDL
24 duplex LC adapters:	FD1W24EIDL

### Opticom™ Pre-Loaded Fibre Drawer for OM2 50/125µm Multimode Fibre – Phos. Bronze Sleeve

6 duplex SC adapters:	FD1W6BLDSC
12 duplex SC adapters:	FD1W12BLDSC
24 duplex SC adapters:	FD1W24BLDSC
12 duplex LC adapters:	FD1W12BLDL
24 duplex LC adapters:	FD1W24BLDL

### Opticom™ Pre-Loaded Fibre Drawer for OM3/OM4 50/125µm Multimode Fibre – Zirconia Split Sleeve

6 duplex SC adapters:	FD1W6AQDSCZ
12 duplex SC adapters:	FD1W12AQDSCZ
24 duplex SC adapters:	FD1W24AQDSCZ
12 duplex LC adapters:	FD1W12AQDLZ
24 duplex LC adapters:	FD1W24AQDLZ

### Opticom™ Pre-Loaded Fibre Drawer for OS1/OS2 9/125µm Singlemode Fibre – Zirconia Split Sleeve

6 duplex SC adapters:	FD1W6BUDSCZ
12 duplex SC adapters:	FD1W12BUDSCZ
24 duplex SC adapters:	FD1W24BUDSCZ
12 duplex LC adapters:	FD1W12BUDLCZ
24 duplex LC adapters:	FD1W24BUDLCZ
12 duplex E-2000 adapters:	FD1W12BUDE2KZ
24 duplex E-2000 adapters:	FD1W24BUDE2KZ

### Opti-Core™ Patch Cords and Pigtails

Duplex SC to SC patch cords:	F <sup>A</sup> LD3-3M‡
Simplex SC to buffered pigtail:	F <sup>A</sup> B3-NM‡Y
Duplex LC to LC patch cords:	F <sup>A</sup> LE10-10M‡
Simplex LC to buffered pigtail:	F <sup>A</sup> B10-NM‡Y
Simplex E-2000 to buffered pigtail (singlemode only):	F9B16-NM‡

### Opticom™ Splicing Accessories

Fibre splice chip, 24 fusion splices:	FSC24
Fibre splice module, 24 fusion splices:	FOSMF
Fibre splice module, 12 mechanical splices:	FOSMM

<sup>^</sup>Substitute for fibre type 6 (OM1 – 62.5/125µm), 5 (OM2 – 50/125µm), X (OM3/OM4 – 10GigE™ 50/125µm) and 9 (OS/OS2-9/125µm).

‡Substitute for length in metres: Patch cords – 1 – 10, 15, 20, 25 or 30; pigtails – 1, 2 or 3. Contact Customer Service for other available lengths.

# Opticom™ Pre-Loaded Fibre Drawers

## pre-loaded fibre drawer dimensions

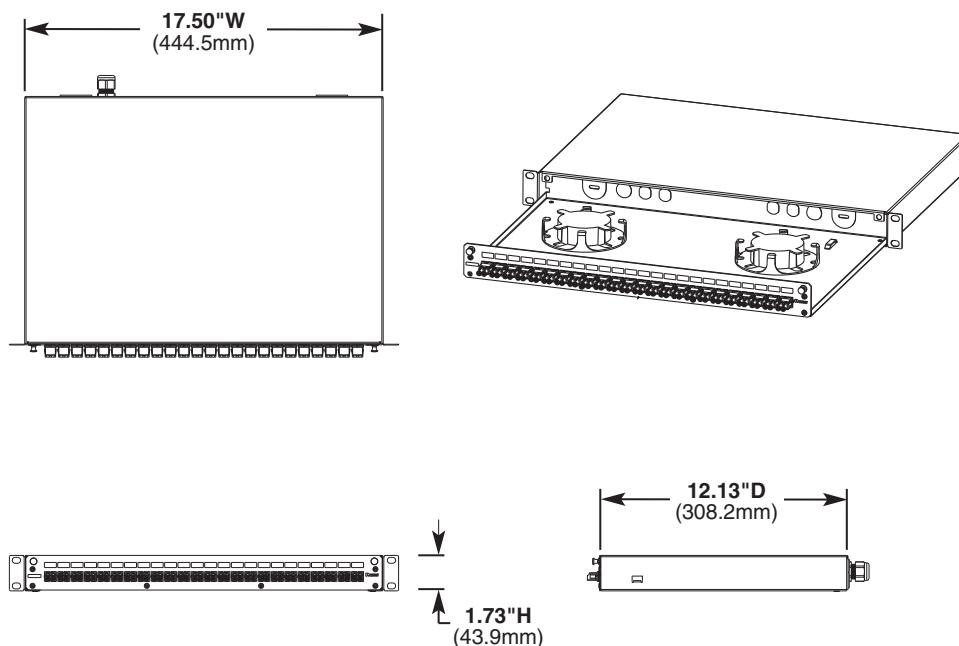

### FD1W<sup>^</sup> (adapter counts and types vary based on part number configuration)

Substitute for adapter colour/fibre type: EI (Electric Ivory/OM1 62.5/125µm), BL (Black/OM2 50/125µm), AQ and add Z to end (Aqua/OM3/OM4 10Gig or BU and add Z to end (Blue/OS1/OS2 9/125µm).

<sup>^</sup> = Adapter counts and types vary based on part number configuration

Dimensions are in millimetres

#### WORLDWIDE SUBSIDIARIES AND SALES OFFICES

PANDUIT CANADA  
Markham, Ontario  
cs-cdn@panduit.com  
Phone: 800.777.3300

PANDUIT EUROPE LTD.  
London, UK  
cs-emea@panduit.com  
Phone: 44.20.8601.7200

PANDUIT SINGAPORE PTE. LTD.  
Republic of Singapore  
cs-ap@panduit.com  
Phone: 65.6305.7575

PANDUIT JAPAN  
Tokyo, Japan  
cs-japan@panduit.com  
Phone: 81.3.6863.6000

PANDUIT LATIN AMERICA  
Guadalajara, Mexico  
cs-la@panduit.com  
Phone: 52.33.3777.6000

PANDUIT AUSTRALIA PTY. LTD.  
Victoria, Australia  
cs-aus@panduit.com  
Phone: 61.3.9794.9020

For a copy of Panduit product warranties, log on to [www.panduit.com/warranty](http://www.panduit.com/warranty)

For more information

Visit us at [www.panduit.com](http://www.panduit.com)

Contact Customer Service by email: [cs@panduit.com](mailto:cs@panduit.com)  
or by phone: 800.777.3300 and reference RKSP108

**PANDUIT**®

©2012 Panduit Corp.  
ALL RIGHTS RESERVED.  
RKSP108--WW-ENG  
Replaces WW-RKSP42-GB  
11/2012