



## ATX™ FNLED SERIES NONMETALLIC LED LUMINAIRES

### FEATURES

- Easy to retrofit in same mounting footprint as Appleton's FE series nonmetallic fluorescent luminaires.
- Full range of lumen outputs, with light distribution equivalent to Appleton's FE series fluorescent luminaires.
- Corrosion-resistant fiberglass reinforced polyester body and hinged polycarbonate lens.
- High impact resistance housing (20 Joules IK10) from -30 °C to +55 °C (-22 °F to +131 °F) ambient temperature and wind profile for use in extreme offshore and onshore environments.
- 60,000+ hour LED life at +55 °C (+131 °F) ambient for years of maintenance free operation.
- Lightweight design, hinged cover with captive screws, and terminal block wiring for easy installation and maintenance.
- Contemporary, low profile design suitable for tight spaces.
- Standard screw-type terminal block can accept 1.5 to 6 mm<sup>2</sup> wire.
- Field replaceable LED driver.
- Industry-leading thermal management for safe, reliable operation over wide temperature range.
- Universal, high efficiency, drivers cover voltage requirements for 120-277 Vac, 125-300 Vdc, 50/60 Hz +/- 10%.
- High power factor electronic driver (>0.95).
- Standard 6KV surge suppression.
- M20 plug or M25 plug provided.
- Latch assembly and elastomer gasket seals against water and dust ingress, IP66.
- Easily accessed for maintenance using Hex or Allen key or straight blade screwdriver.
- Central opening with unique patented release system to prevent damage.

- Can be horizontally or vertically mounted.
- Available in 5000K and 4000K Color Temperatures
- Meets Photobiological Requirement for Risk Group 0 (RG0).

### SUITABLE LOCATIONS

- For use in locations where:
  - Hazardous areas are designated as Zone 2 and 22
  - A high degree of corrosion resistance is required
  - Protection against dirt, water and moisture is necessary
- Typical applications include:
  - Oil refineries
  - Petrochemical facilities
  - Food processing plants
  - Waste and water treatment plants
  - Underground tunnels
  - General manufacturing facilities

### STANDARD MATERIALS

- Housing: fiberglass reinforced polyester
- Lens: polycarbonate
- Diffuser: polycarbonate
- Gasket: elastomer
- Internal reflector: highly reflective white polycarbonate (standard versions) or powder coated aluminum (emergency versions)
- Mounting accessories available in different materials such as gray painted aluminum, zinc plated steel, galvanized steel or 316 stainless steel

### ATEX/IECEX CERTIFICATIONS AND COMPLIANCES

- **Certification Type: FELED30**
  - Gas: Zone 2
    - Conforming to ATEX 2014/34/EU: II 3 G
    - Type of Protection: Ex ec IIC Gc
    - Temperature Class: T5 to T3
  - Dust: Zones 22
    - Conforming to ATEX 2014/34/EU: II 3 D
    - Type of Protection: Ex tc IIIC Dc
    - Surface Temperature: +60 °C to +80 °C (+140 °F to +176 °F)
- Ambient Temperature: -30 °C up to +55 °C (-22 °F up to +131 °F)
- EU Declaration of Conformity: 50319
- ATEX Certificate: INERIS 19 ATEX 3005X
- IECEx Certificate: INE 19.0006X
- Index of Protection according EN/IEC 60529: IP66
- Impact Resistance (shock): IK10
- Photobiological Safety, IEC 62778 and IEC 62471: RG0

APPLETON™

For product information:  
[www.masteringled.com](http://www.masteringled.com)  
 1.800.621.1506



CONSIDER IT SOLVED™

# ATX™ FNLED SERIES NONMETALLIC LED LUMINAIRES

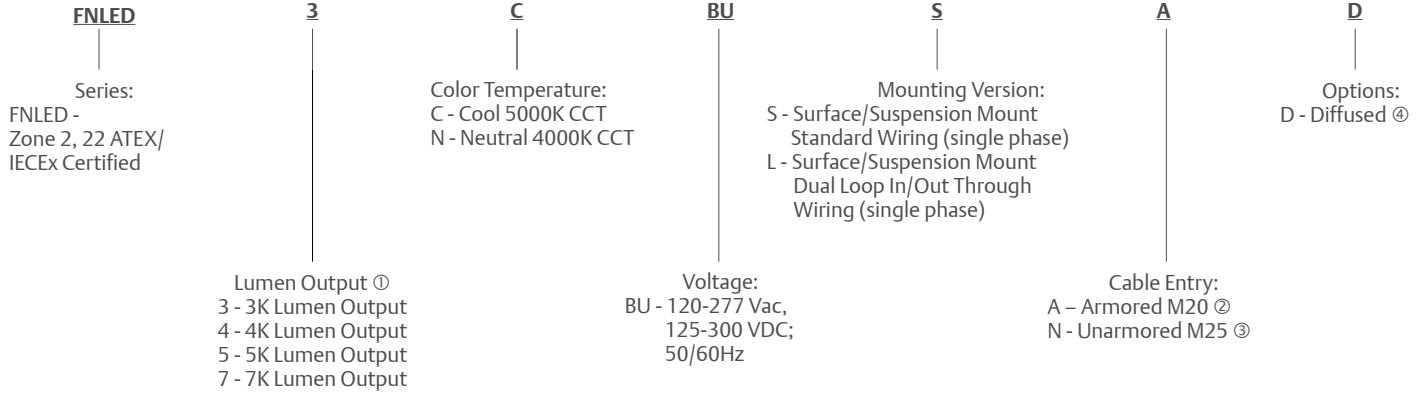

- ① All values displayed reflect typical values.
- ② Must order armored cable glands separately.
- ③ Cable glands provided in luminaires with unarmored hub entries.
- ④ Diffused option required for FNLED series.

## Product Specifications

	FNLED3BU				FNLED4BU				FNLED5BU				FNLED7BU			
	SA	SN	LA	LN	SA	SN	LA	LN	SA	SN	LA	LN	SA	SN	LA	LN
Line Current Amps	0.132A at 230 Vac				0.173A at 230 Vac				0.193A at 230 Vac				0.296A at 230 Vac			
Input Power	30				40				43				66			
Power Factor	>0.9															
Correlated Color Temperature (CCT)	5000K		4000K		5000K		4000K		5000K		4000K		5000K		4000K	
Color Rendering Index (CRI)	80+															
Lumen Output	3,300		3,200		4,300		4,200		5,100		5,000		7,000		7,000	
Efficacy (Lumens per watt)	112		108		111		108		117		115		106		106	
Luminaire Length	0.785 m (2.58 ft)								1.39 m (4.56 ft)							
Lifetime (L70B10)	60,000+ hours															